

Product Brochure For W08260

3000 x 1500mm M28 Pro Series Welding Table - WT28-3015N

Plasma Nitriding Coating
 Ø28mm Holes

On Sale

Ex GST	Inc GST
\$10,450.00	\$11,495.00
\$9,500.00	\$10,450.00



ORDER CODE:	W08260
MODEL:	WT28-3015N
Table Hole Diameter (Ø):	28
Table Top Finish (Type):	Plasma Nitriding Coating
Table Top Size (mm):	3000 x 1500
Grid Pattern (mm/Type):	100 x 100 / Diagonal
Table Height (mm):	700-860
Table Side Height (mm):	200
Top Plate Thickness (mm):	25
Table Slots (mm):	~
Static Load Capacity (kg):	6000
Total W.L.L. (kg):	~
Number of Legs (No.):	8
Nett Weight (kg):	1380

METALMASTER



Description

When accuracy, strength and reliability matter, the Metalmaster M28 Pro Series Welding Table delivers uncompromising performance for professional fabricators. Manufactured from heavy-duty S355 steel and engineered with advanced CNC machining technology, the Pro Series provides an exceptionally flat, durable and versatile work surface designed to maximise productivity on every project.

Every table begins with a fully welded, interlocking rib construction that creates an incredibly rigid foundation capable of handling demanding fabrication work. The tabletop and sides are CNC machined to a finished 25mm thickness, achieving an outstanding flatness tolerance of ±0.1mm over 1m² for precision assembly and welding.

Precision doesn't stop at the surface. Each Ø28mm fixture hole is CNC bored to an exact tolerance of ±0.05mm, ensuring perfect compatibility with professional fixturing systems. The newly radiused hole edges allow fixtures and clamps to slide into place smoothly, making setup faster, easier and more efficient.

The industry-standard 100 x 100mm diagonal hole pattern, complete with an additional centre hole, provides virtually unlimited clamping and fixturing possibilities for projects of every size. Precision-engraved 100mm grid lines and a perimeter ruler allow accurate positioning, helping reduce errors while increasing productivity.

To ensure years of dependable service, every M28 Pro Series table receives a plasma nitriding treatment that thermochemically hardens the surface. This premium finish dramatically improves resistance to weld spatter, wear and corrosion while maintaining the precision-machined surface.

Designed for serious fabrication environments, the Pro Series features 200mm high reinforced sides, interlocking solid steel ribs and adjustable heavy-duty legs fitted with 125mm lockable swivel castors, providing outstanding stability with the flexibility to move your workstation wherever it's needed.

Complete your setup with Metalmaster's extensive range of Pro Series clamps, stops and fixturing accessories to create the ultimate modular welding system. Whether you're fabricating one-off custom work or tackling large production jobs, the M28 Pro Series gives you the precision, durability and versatility to take on every project with confidence.

Features

- Heavy-duty 25mm S355 steel tabletop and sides
- Precision CNC machined to ±0.1mm flatness over 1m²
- Ø28mm precision-bored fixture holes with ±0.05mm accuracy
- Radiused holes for smoother fixture and clamp insertion
- Industry-standard 100 x 100mm diagonal hole pattern with additional centre holes

Product Brochure For W08260

- Precision engraved 100mm grid lines and perimeter ruler
- Plasma nitrided surface for superior hardness, rust, wear and spatter resistance
- Reinforced interlocking rib construction for maximum rigidity
- 200mm high sidewalls for exceptional load capacity
- Adjustable heavy-duty legs with lockable 125mm swivel castors

Includes

- 8pcs of adjustable heavy steel legs c/w swivel caster with brake

Optional Accessories

- 42pc Welding Clamp Set (W08280)
- It is recommended that a minimum of 2 pairs (4pcs) of the WT28-LFK2 - Table & Accessory Lifting Kit (W08290) when lifting

Specific Features



Adjustable Table Height 700 860mm



Plasma Nitriding Surface Finish



Radius Edge Holes



28mm Diameter Holes

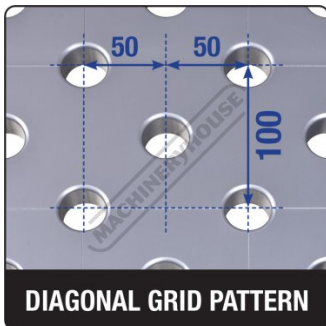

Diagonal Grid Pattern



Perimeter Ruler Engravings



200mm High Sides



Approx 25mm Thick



Swivel Brake Wheels

Product Brochure For W08260

Recommended Accessories

W08290

Table & Accessory Lifting Kit



W08280

42pc Welding Table Clamping & Fixturing Kit



W08282

96pc Welding Table Clamping & Fixturing Kit

