

Product Brochure For W08227

## 2400 x 1200mm M28 Cast Iron Series Welding Table - WT28-2412CST

Heavy Duty Cast Iron  
 Ø28mm Holes

**New Release**

**Ex GST**                      **Inc GST**  
**\$3,650.00**                    **\$4,015.00**



ORDER CODE:	W08227
MODEL:	WT28-2412CST
Table Top Finish (Type):	Cast Iron
Table Top Size (mm):	2400 x 1200
Table Height (mm):	800
Table Side Height (mm):	210
Top Plate Thickness (mm):	28
Grid Pattern (mm):	100 x 100
Table Hole Diameter (Ø):	28
Table Slots (mm):	~
Static Load Capacity (kg):	3000
Total W.L.L. (kg):	~
Number of Legs (No.):	6
Nett Weight (kg):	866



### Description

The Metalmaster M28 Cast Iron Series welding tables features heavy-duty cast-iron construction making them the most economical series of our 28mm welding tables. All our M28 Cast Series are manufactured from ISO grade 150 grey cast iron offering high thermal conductivity for uniform heat distribution as well as being naturally resistant to spatter preventing the workpiece from adhering to the table.

The frame is produced using a sand-casting method then CNC machined with the top having a finished nominal thickness of 26-28mm & the 200mm deep sides having a nominal thickness of 20-22mm. The CNC machining process is able to achieve a flatness tolerance of +/- 0.1mm over 1m<sup>2</sup> to give you a smooth precision welding surface. During this CNC machining process, the Ø28mm holes are precision bored to ensure a hole distance tolerance of +/- 0.05mm & with a 100 x 100mm grid hole pattern it gives you a multitude of fixture holes to suit your application.

Our M28 Cast Series tables have been designed with an internal intersecting rib structure along with 200mm high sides to maintain rigidity & heavy load capacity for all heavy fabrication projects. The table also comes complete with heavy powder coated tube steel legs featuring levelling feet ensuring a stable working surface. Choose from our wide range of optional Pro Series clamping kits & fixturing accessories to add to your table giving you the ultimate welding & fixturing system for your next fabrication project.

### Features

- Raw cast iron machined surface finish making it naturally spatter resistant
- Ø28mm Precision bored fixing holes at 100mm centres
- 100 x 100mm hole grid pattern offering a multitude of clamping options
- Precision CNC machined to ensure flatness of +/- 0.1mm over 1m<sup>2</sup>
- Manufactured from ISO Grade 150 cast iron

### Includes

- 6pcs of heavy steel legs c/w with leveling feet

### Optional Accessories

- 42pc Welding Clamp Set (W08280)
- It is recommended that a minimum of 2 pairs (4pcs) of the WT28-LFK2 - Table & Accessory Lifting Kit (W08290) when lifting

Product Brochure For W08227

**Specific Features**



800mm Table Height

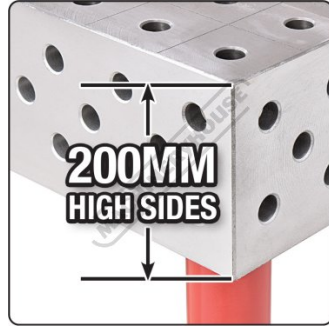

200mm High Sides



Raw Cast Iron Surface Finish

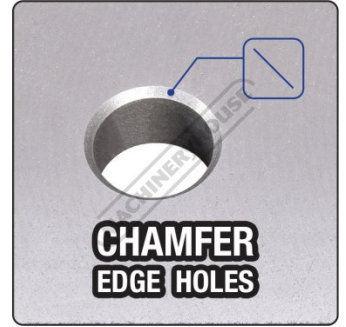

Chamfer Edge Holes

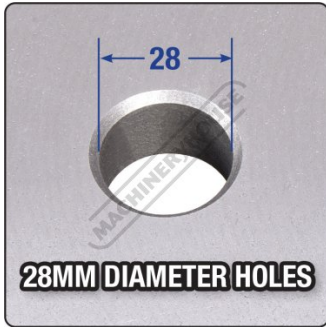

28mm Diameter Holes



26 28mm Top Plate Thickness

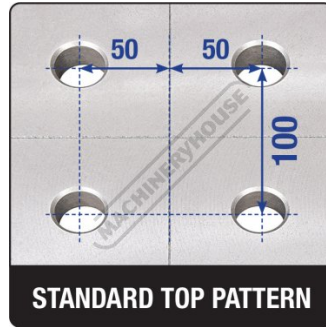

Standard Top Grid Pattern



Diagonal Side Grid Pattern



Levelling Feet

Product Brochure For W08227

**Recommended Accessories**

W08290

Table & Accessory Lifting Kit



W08280

42pc Welding Table Clamping & Fixturing Kit



W08282

96pc Welding Table Clamping & Fixturing Kit

