

Product Brochure For W07812

2400 x 1200mm M16 Pro Series Welding Table - WT16-2412N

Plasma Nitriding Coating
 Ø16mm Holes

Ex GST **Inc GST**
\$6,290.00 **\$6,919.00**



ORDER CODE:	W07812
MODEL:	WT16-2412N
Table Hole Diameter (Ø):	16
Table Top Finish (Type):	Plasma Nitriding Coating
Table Top Size (mm):	2400 x 1200
Grid Pattern (mm/Type):	50 x 50 / Standard
Table Height (mm):	665-900
Table Side Height (mm):	100
Top Plate Thickness (mm):	12
Table Slots (mm):	~
Static Load Capacity (kg):	3000
Total W.L.L. (kg):	~
Number of Legs (No.):	6
Nett Weight (kg):	431



Description

When accuracy, strength and reliability matter, the Metalmaster M16 Pro Series Welding Table delivers uncompromising performance for professional fabricators. Manufactured from heavy-duty S355 steel and engineered with advanced CNC machining technology, the Pro Series provides an exceptionally flat, durable and versatile work surface designed to maximise productivity on every project. Every table begins with a fully welded, interlocking rib construction that creates an incredibly rigid foundation capable of handling demanding fabrication work. The tabletop and sides are CNC machined to a finished 12mm thickness, achieving an outstanding flatness tolerance of ±0.1mm over 1m² for precision assembly and welding.

Precision doesn't stop at the surface. Each Ø16mm fixture hole is CNC bored to an exact tolerance of ±0.05mm, ensuring perfect compatibility with professional fixturing systems. The newly radiused hole edges allow fixtures and clamps to slide into place smoothly, making setup faster, easier and more efficient.

The industry-standard 50 x 50mm hole pattern provides closely spaced clamping points for precise positioning and versatile fixturing. Precision-engraved 50mm grid lines and a perimeter ruler allow accurate positioning, helping reduce errors while increasing productivity.

To ensure years of dependable service, every M16 Pro Series table receives a plasma nitriding treatment that thermochemically hardens the surface. This premium finish dramatically improves resistance to weld spatter, wear and corrosion while maintaining the precision-machined surface.

Designed for serious fabrication environments, the Pro Series features 100mm high reinforced sides, interlocking solid steel ribs and adjustable heavy-duty legs fitted with 125mm lockable swivel castors, providing outstanding stability with the flexibility to move your workstation wherever it's needed.

Complete your setup with Metalmaster's extensive range of Pro Series clamps, stops and fixturing accessories to create the ultimate modular welding system. Whether you're fabricating one-off custom work or tackling large production jobs, the M16 Pro Series gives you the precision, durability and versatility to take on every project with confidence.

Features

- Heavy-duty 12mm S355 steel tabletop and sides
- Precision CNC machined to ±0.1mm flatness over 1m²
- Ø16mm precision-bored fixture holes with ±0.05mm accuracy
- Radiused holes for smoother fixture and clamp insertion
- Industry-standard 50 x 50mm standard hole pattern
- Precision engraved 50mm grid lines and perimeter ruler
- Plasma nitrided surface for superior hardness, rust, wear and spatter resistance

Product Brochure For W07812

- Reinforced interlocking rib construction for maximum rigidity
- 100mm high sidewalls for exceptional load capacity
- Adjustable heavy-duty legs with lockable 125mm swivel castors

Includes

- 6pcs of adjustable heavy steel legs c/w swivel caster with brake

Optional Accessories

- It is recommended that a minimum of 2 pairs (4pcs) of the WT16-LFK2 - Table & Accessory Lifting Kit (W07820) when lifting

Specific Features



Adjustable Table Height 665 900mm

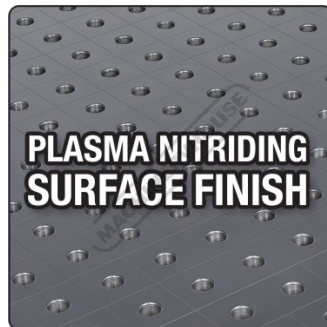

Plasma Nitriding Surface Finish



Radius Edge Holes



16mm Diameter Holes

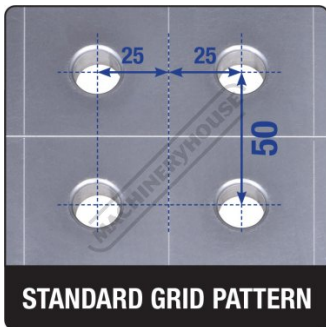

Standard Grid Pattern



Perimeter Ruler Engravings

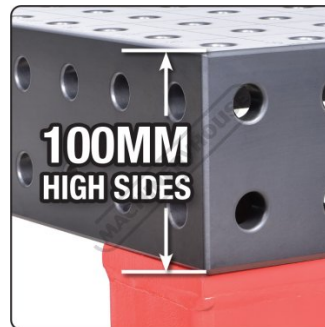

100mm High Sides



Approx 12mm Thick



Swivel Brake Wheels

Product Brochure For W07812

Recommended Accessories

W07814

52pc Pro Series Welding Table
Clamp Kit

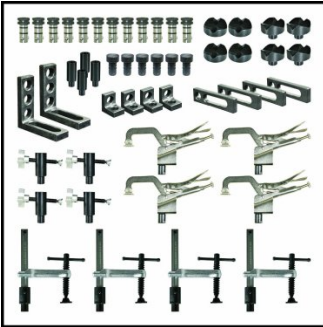

W07815

70pc Pro Series Welding Table
Clamp Kit

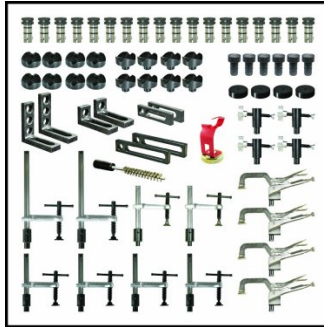

W07816

93pc Pro Series Welding Table
Clamp Kit

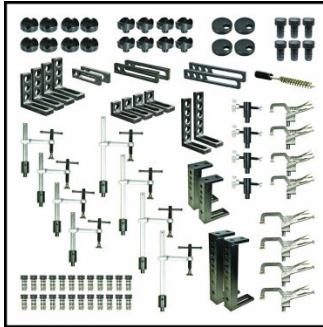

W07817

120pc Pro Series Welding Table
Clamp Kit

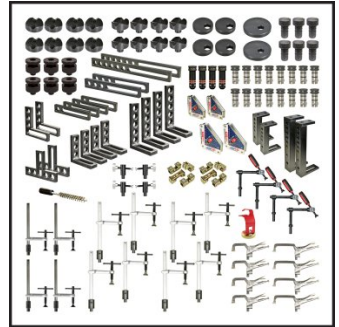

W07818

151pc Pro Series Welding Table
Clamp Kit

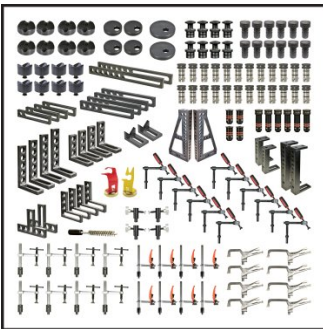

W07820

Table & Accessory Lifting Kit

