

Product Brochure For V311

Modular Machine Vice

152mm Jaw Width
 200mm Jaw Opening

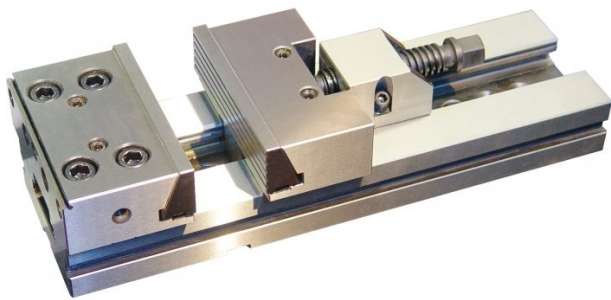

Ex GST **Inc GST**
\$1,050.00 **\$1,155.00**

ORDER CODE:	V311
A - Jaw Width (mm):	152
C - Jaw Opening (mm):	200
B - Jaw Height (mm):	50
D (mm):	420
E (mm):	500
F (mm):	50
G (mm):	125
H (mm):	90
Nett Weight (kg):	30

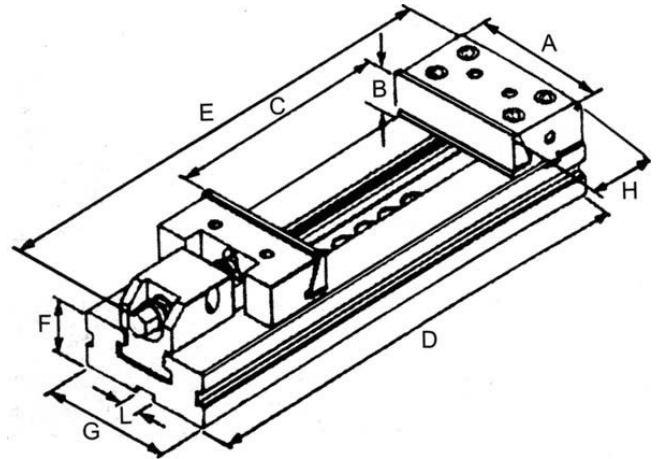

Description

Toolmaster vices are manufactured under rigid quality control. All Toolmaster vices are interchangeable and can be used as matched pairs.

Features

- Hardened and ground steel to HRC60, with high precision
- Keyways are 16mm H7 and are toleranced giving perfect alignment and reducing set up time
- Space saving design allows for maximum use of clamping area

Product Brochure For V311

Recommended Accessories

V3112
Modular Vice Jaws

