

Product Brochure For T005

Reversible Tapping Chuck - Adjustable Clutch - T4-MT4

Include 3MT & 4MT Arbours

M8 - M20

Ex GST
\$470.00

Inc GST
\$517.00



ORDER CODE:	T005
MODEL:	T4-MT4
Arbor Mount:	Threaded
Taper (MT):	3 & 4
Tapping Range (mm):	8 - 20
Tapping Shank Size (mm):	6.3 - 14
D (mm):	90
D1 (mm):	38
L (mm):	195
L1 (mm):	134
A (mm):	62
B (mm):	20
Nett Weight (kg):	6.8



Features

- Pre-select torque drive to prevent tap breakage and allow for blind hole tapping
- Tension and compression feature compensates between rate of feed applied and thread pitch
- Suitable for right and left hand, vertical and horizontal tapping
- Fast tap reversal. Re-entry cushioning eliminates cross threading
- Clutch Torque Setting:
 - 1 - 12 Nm
 - 2 - 20 Nm
 - 3 - 60 Nm
 - 4 - 110 Nm

• Please Note: M20 tap requires a 14mm Shank

Includes

- MT3 & MT4 arbors - threaded end
- 2 x Collet chuck spanners
- 2 x Rubber flex collets
- 2 x allen keys

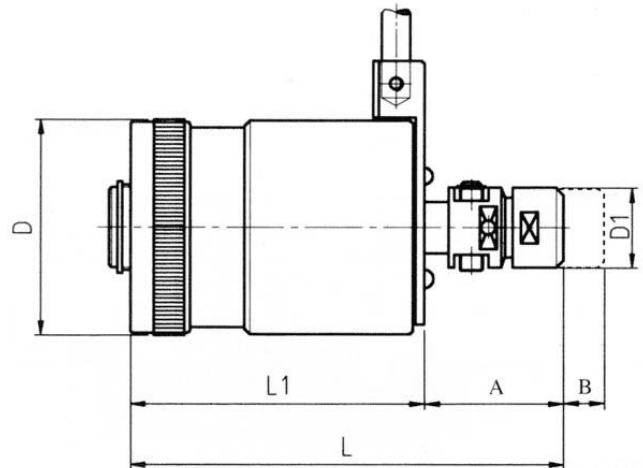

Product Brochure For T005

Specific Features



Full Kit



Blow Mold Case

Recommended Accessories

T012

Metric Alloy Steel Tap & Die Set
 - 32 Piece



T013

Metric HSS Tap & Die Set - 32
 Piece



T014

Metric Alloy Steel Tap & Die Set
 - 45 Piece



T015

Imperial Alloy Steel Tap & Die
 Set - 45 Piece



T016

Metric HSS Tap & Die Set - 45
 Piece

