

## Product Brochure For S910

### Hydraulic NC Pressbrake - PB-170B

176T x 4000mm

Estun NC-E21 Control 2-Axis with Ballscrew Backgauge & Table Crowning



ORDER CODE:	S910
MODEL:	PB-170B
Control Unit (Type):	Estun NC-E21
Nominal Pressure - Tonnage (Ton):	176
Nominal Pressure - Kilonewtons (kN):	1600
Length of Work Table (mm):	4000
Distance Between Columns (mm):	3200
Throat Depth (mm):	420
Maximum Open Height (mm):	470
Ram Stroke (mm):	200
Machine Axis (No.):	2
Safety Guarding System (Type):	~
Backgauge Travel (mm):	550
Table Bed Crowning System (Type):	Mechanical Crowning System
Motor Power (kW / hp):	11 / 15
Motor Voltage (V):	415
Floor Space Requirements (L x W x H) (mm):	4700 x 2200 x 2900
Nett Weight (kg):	14100



### Description

MetalMaster Quality Pressbrakes feature high durability, and provide precision bending capabilities. The Pressbrake main frames are constructed from rolled, stress relieved solid steel to prevent distortion during the bending process and under extreme continuous loads.

MetalMaster Pressbrakes are produced in a high volume production process and therefore are able to be manufactured cost effectively, resulting in affordable price, representing value for money and quicker return on investment.

Featuring an adjustable synchronised torsion bar with positive stop system ensures consistent and accurate bending beam parallelism tolerance to 0.01mm via the digital Control unit.

All electrical components are of European quality supplied by, Telemecanique, Merlin Gerin and ABB.

Note: Guarding systems are required on pressbrakes for OHS compliance. See options below

### Features

- Hydraulic / Mechanical ram, synchronised positive stop design, ram stroke controlled by precision mechanical nut depth stops built into each cylinder. Electronically controlled by Estun NC-E21 Programmable digital control assuring accurate repeatability.
- Parallelism is ensured by torsion bar that can be easily adjusted by clutch system.
- Estun NC-E21 programmable digital control stores up to 40 unique programs with 25 automatic progressive bending steps in each individual program, assuring production accuracy & repeatability every time.
- Estun NC-E21 programmable hardened ballscrew backgauge system, simply enter the desired measurement into the controller and press go, the backgauge then will move quickly into the position you have requested. The superior hardened ballscrew system eliminates any backlash that leadscrew type machines produce.
- Manual crowning system allows operator to adjust table bed to correct the deflection than can occur towards the centre of the pressbrake
- Segmented heavy duty 86° offset top punch is segmented for return bend clearance, complete with European style quick release punch holder with an adjustable wedge clamping system for crowning. Intermediate clamp has safety key to stop punch dropping.
- Multi vee ('V') bottom die is made from one 4000mm solid die block design to handle heavy plate, safety edge vee ('V') is incorporated in bottom die block.
- Conveniently mounted control box on pendant for quick swivel and adjustments.
- Mono-block steel frame design, welded then machined to ensure minimal bed deflection under load
- Enclosed rear gate with micro safety switches complete with sliding rear door for easy access.
- European Intermediate clamping system, allowing operator to change position of tooling to suit multiple requirements on complex applications. This feature ensures minimum down time, more productivity and results in reduced cost per finished product.
- Sliding steel fabricated sheet supports enabling a wide range of material sizes to be aligned and supported at the correct required height. This feature is achieved with a "T" slot machined down the total length of the die bed sheet supports are also adjustable vertically to assist

## Product Brochure For S910

---

- in supporting material with return bends already folded.
  - Adjustable sliding blocks control the machines beam to provide desirable open height distance to the (slow speed) mute bending point. Operator adjustable locking knobs for quick adjustment, enables accurate repeatability and increased productivity.
  - Metal safety guarding surrounding the machine with rear sliding door fitted and micro switch ensuring operator safety. Clear access panels placed at each end of machine allows the operator to clearly view tooling and work piece during bending operation. MetalMaster specially design gates to suit Australian safety requirements.
  - Hydraulic MPA pressure gauge mounted on right side of support frame with quick adjusting pressure control knob allowing operator to accurately set the pressure required for different material thickness, incorporating with hydraulic overload protection.
  - Welded steel fabricated synchronised torsion bar horizontally supporting main bending beam to provide consistent parallelism that also can be adjusted for taper correction.
  - The vertical supporting slides are treated to provide greater wear resistance and increased accuracy.
  - Reinforced side frames providing addition support strength to machine throat
  - Mild steel capacity is rated on hot rolled material with 250MPA
- Pre-Commissioning:
    1. Pressbrake is run & tested prior delivery
    2. Hydraulic oil is included with machine

### **Includes**

- Operated by ESTUN NC- E21 control mounted on a swivel pendant for optimal ergonomics
- LED superior bright work lights provides clearer view to workpiece
- Sliding front sheet support arms
- Manual bed crowning system
- Emergency stop buttons conveniently located on control panel and foot control
- Mobile dual operation foot control
- 86 Degree Top Punch with Segments (4x800, 1x365, 1x200, 1x100, 1x50, 1x40, 1x20, 1x15, 1x10)
- Top tooling tool intermediate holder system with wedge type adjustment
- Multi V bottom die block 130 x 130mm with a range of V's between 8mm~100mm
- Premium linear way side mount ballscrew backgauge with 550mm travel
- Metal constructed safety guarding surrounding machine with clear side viewing panels
- Integrated hydraulic system allowing rapid approach switching automatically to slow bend

**Guarding systems are required on pressbrakes for OHS Compliance, See options below.**

**G Model : Light Curtain Guarding Safety System for OHS Compliance.**

1. Italian made safety light curtains with protection height of 910mm ensures maximum safety for the operator.
2. One of the safest integrated dual channel monitored light curtain systems in Australia.
3. 100% Australian Designed electrical system and safety PLC system.
4. Top beam speed & stopping performance monitoring to ensure maximum safety, in the rare case of hydraulic valve failure.
5. Dual channel monitored safety system independently certified to be compliant with Australian standard AS 4024.1502-2006.



**GL Model : Laser guarding safety system for OHS Compliance.**

1. Laser guarding allows the operator to work closer to the press brake tooling without risk of injury.
2. Italian made Advanced Laser system fully compliant with the requirements of EN61496-1/2, EN12622 as well as AS 4024.1502-2006.
3. One of the safest integrated dual channel monitored safety systems in Australia.
4. 100% Australian Designed electrical system and safety PLC system.
5. Encoder speed & stopping performance monitoring ensures maximum safety in the rare case of hydraulic valve failure.
6. Dual channel monitored safety system has been independently certified to be compliant with Australian standard AS 4024.1502-2006.



Product Brochure For S910

**Specific Features**



Right View



NC Estun E21 Controller



NC Estun E21



Adjustable Travel Limit Control



Intermediate Clamps



Adjustable Top Tool Taper Wedge System



Tooling Clamps



Tooling Clamps Via Screws



Top and Bottom Tooling



Table Crowning Adjustment via Bolts



Table Crowning Adjustment Bolts

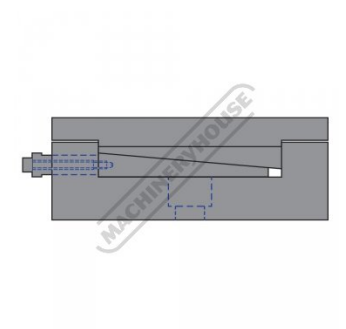

Table Bed Crowning



Enclosed Rear Safety Guarding



Estun NC E21 Control Ballscrew Backgauge

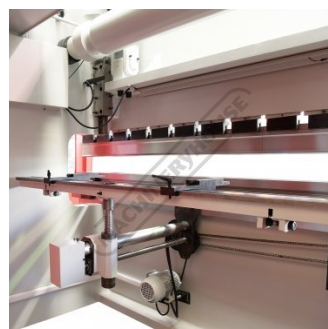

Estun NC E21 Control Ballscrew Backgauge 2



Estun NC E21 Control Ballscrew Backgauge 3

Product Brochure For S910



Motorised Backgauge

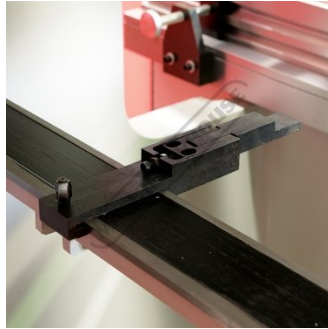

Backgauge Material Stops



Torsion Bar



Adjusting Bottom Stroke Dead Stop Motor



Sheet Supports

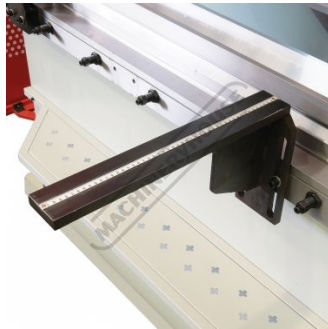

Sheet Supports Close Up



Fine Adjust Backgauge



Adjustable Pressure Gauge

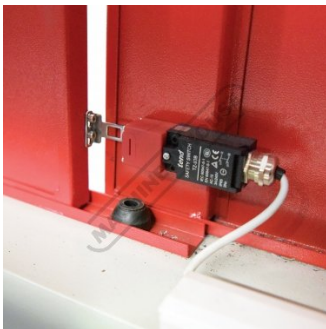

Rear Doors Safety Micro Switch



Mobile Foot Control



Mobile Control Panel

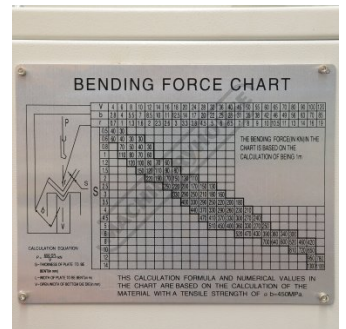

Bending Force Chart

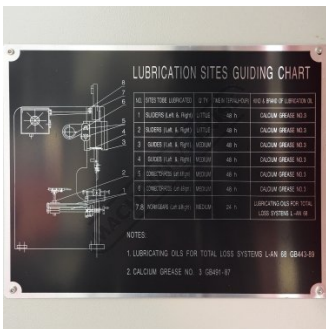

Lubrication Chart

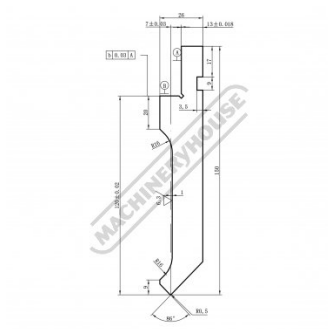

Segmented Top Punch

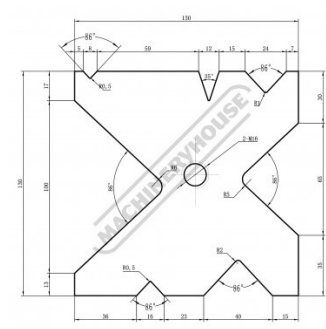

One Piece 4 Sided Die



Shown with Optional Ball Transfer Tables - Order Code (L840)

Product Brochure For S910

**Recommended Accessories**

**S994A**  
 130mm Die Block Pressbrake Tooling

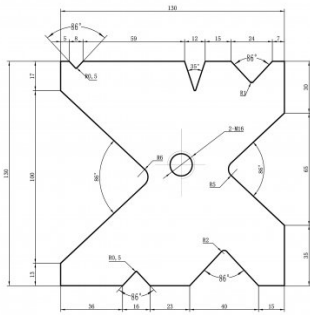

**S991**  
 86° Top Punch Pressbrake Tooling



**S991F**  
 86° Top Punch Pressbrake Tooling



**S990**  
 35° Top Punch Pressbrake Tooling



**S990F**  
 35° Top Punch Pressbrake Tooling



**S997**  
 15° Top Punch Pressbrake Tooling



**S997A**  
 60mm Die Block Pressbrake Tooling

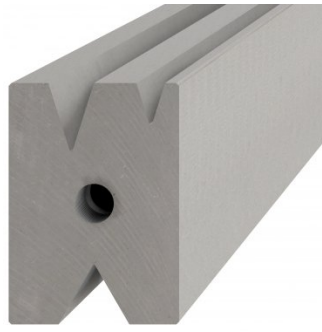

**S997B**  
 60mm Die Rail Pressbrake Tooling



Product Brochure For S910

**S988**  
 Quick Action Intermediate  
 Clamps



**Q200**  
 Combination Set



**Q200A**  
 Combination Set



**Q201**  
 Universal Bevel Protractor



**Q2105**  
 Digital Height Gauge



**M970**  
 Digital Angle Rule



**M972**  
 Digital Angle Rule



**M974**  
 Digital Angle Rule



**M800**  
 Rubber Mat - Anti-Fatigue



**M805**  
 Rubber Mat - Anti-Fatigue

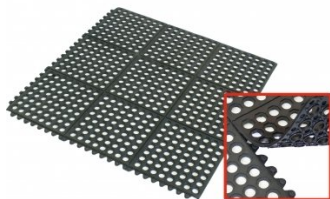

**O000**  
 SpillFix Universal Organic  
 Absorbent



**O043**  
 Rust & Corrosion Preventive



Product Brochure For S910

O042

General Purpose Lubricant & Corrosion Inhibitor



O040

Rust & Corrosion Preventive



O044

Rust & Corrosion Preventive



O004

Superdraulic ISO 46 Hi Temp Hydraulic Oil

