

Product Brochure For S117C

Three Phase Upcut 450mm - TNF125

Mite cutting 90° left, straight 90° and 90° right with rapid adjustment
 450mm Blade, Twin Pneumatic Vice Clamps, Variable Blade Speed
 3200rpm



Special Order

Ex GST

Inc GST

\$11,100.00 \$12,210.00

| | |
|---|-------------------|
| ORDER CODE: | S117C |
| MODEL: | TNF125 |
| Cutting Head Action (Auto-Manual): | Semi-Automatic |
| Operation Type: | ~ |
| Round Capacity @ 90° / 45° (mm): | 296 / 205 |
| Square Capacity @ 90° / 45° (mm): | 296 / 205 |
| Rectangle Capacity @ 90° / 45° (mm): | |
| Compound Rectangle Capacity @ 45° x 45° (mm): | ~ |
| Compound Square Capacity @ 45° x 45° (mm): | ~ |
| Blade Size (D x B x T) (mm): | 450 x 30 x 4 |
| Number of Teeth (No.): | ~ |
| Vice Clamping Fixture: | Pneumatic Vices |
| Coolant System: | ~ |
| Table Working Height (with Stand) (mm): | 1250 |
| Blade Speeds (rpm): | 3200 |
| Motor Power (kW / hp): | 5 / 6.7 |
| Voltage (V): | 415 |
| Machine Dimension (mm): | 965 x 6840 x 1400 |
| Nett Weight (kg): | 270 |



Description

Brobo - Aluminium Manual Saw

Features

- Mitering 90° left, straight 90° and 90° right with rapid adjustment bumpers
- Adjustable cutting speed
- Vertical pneumatic clamping
- Fully enclosed lid/guard with protective power supply shut down
- Power source protects against abrupt changes in voltage
- Saw exit speed regulator brings down speed in aluminium cutting, thus enables decreasing engine load
- Ø 450mm TCT Blade
- Two feed roller conveyors (3m long each)
- 3m Adjustable length stop

Includes

- 3 metre Infeed roller conveyors
- 3 metre outfeed roller conveyor
- 3 metre adjustable length stop

Product Brochure For S117C

Specific Features



Attachable 2 x 3m Feed Roller Conveyors



Pneumatic Clamps-Work Surface



Control Panel



Blade Speed Control



Air Regulator & Oiler



Air Hose

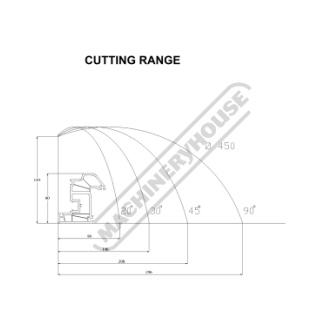

TNF125 Cutting Chart