

Product Brochure For Q491

# Groove Micrometer - 11-491

25-50mm

ORDER CODE:	Q491
Inside Range (mm):	26.5 - 51.5
Outside Range (mm):	25-50
Parallelism (mm):	0.01
Accuracy (mm):	0.01
D (mm):	13

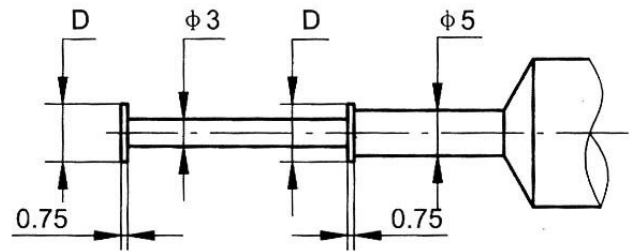
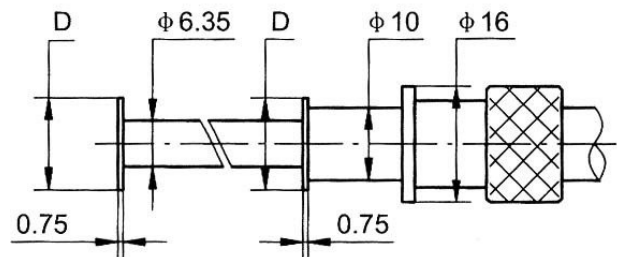

## Description

Measumax Groove Micrometers provide a easy method for measuring recesses in bores such as hydraulic seals "O" ring grooves and Circlip grooves.

## Features

- Flanged measuring faces for measuring the locations of grooves inside bores
- Laser engraved graduations
- Two scales provided for inside and outside measurement
- Two-directional measuring force
- Resolution: 0.01mm

Product Brochure For Q491

---

**Specific Features**

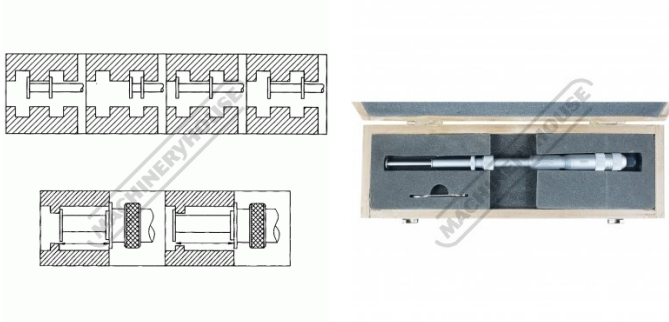

Figure 1.gif

Shown In Box