

Product Brochure For Q211

Metric Dial Indicator - 34-211

0-10mm
 Smooth movement



Features

- Face Ø58mm - Back plate mounting lug
- Smooth movement
- In-out tolerance marker
- Supplied in foam lined plastic case with calibration certificate

Ex GST
\$75.00

Inc GST
\$82.50

ORDER CODE:	Q211
Range (mm / inch):	0 - 10mm
Graduations (mm / inch):	0.01mm
A (mm):	40
B (mm):	21
C (mm):	8
D (mm):	58
E (mm):	19
F (mm):	17
G (mm):	6.35
H (mm):	8

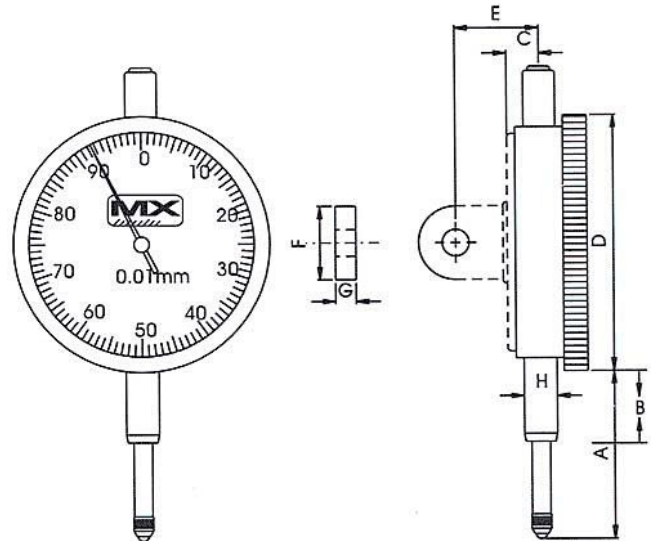

Product Brochure For Q211

Recommended Accessories

Q2165
 Ø10mm Flat Contact for Dial Indicators



Q2167
 Contact Point for Dial Indicators



Q2125
 Back Plate with Lug for Dial Indicators



M050
 Magnetic Base - Standard



M051
 Magnetic Base - Deluxe - One Lock



Q430
 Magnetic Base - Small



Q435
 Magnetic Base - Large



Q4351
 Magnetic Base - Large



Product Brochure For Q211

Q436

Magnetic Base - One Lock
(Large)

