

Product Brochure For Q133

Indicator Snap Micrometer - 10-133

25-50mm

ORDER CODE:	Q133
Range (mm):	25 - 50
Accuracy (mm):	0.001
L (mm):	53.5
D (mm):	35

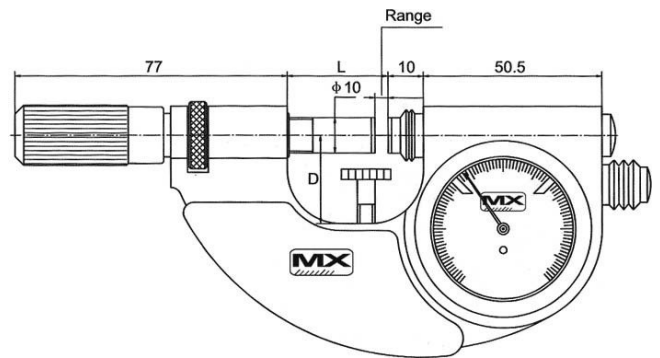

Features

- Protection level IP54
- 10mm diameter carbide measuring faces
- Direct GO/NOGO judgment for mass produced parts
- Measuring force 5-10N
- Painted frame
- Carbide tipped anvils, Flatness 0.0008mm
- Indicator rang ± 0.04 mm
- Indicator resolution 0.001mm

Product Brochure For Q133

Specific Features



Test Piece



Test Piece



Rear Side