

Product Brochure For M528

Face Mill 90° - Positive Rake - ME32TMT x 3MT

Ø32mm

Insert tip not included

Ex GST
 \$80.00

Inc GST
 \$88.00



ORDER CODE:	M528
MODEL:	ME32TMT
Cutter Approach Angle (deg):	90°
D (mm):	32
D1 (mm):	~
H (mm):	~
d (lowercase):	3MT
Drawbar Thread:	1/2" whitworth
Number of Inserts (No.):	2
Replacement Insert Tips:	(L066)
Nett Weight (kg):	0.50

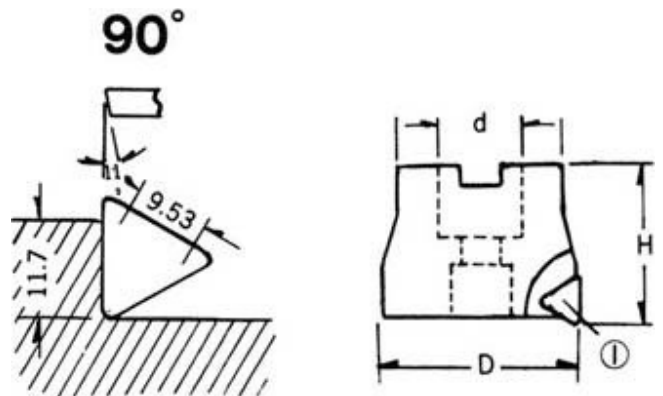

Description

POSITIVE RAKE FACE MILL - 32mm x 90°
 Use carbide inserts (ISO) TPKN1603 (L0661) or TPMN1603 (L066)
 NOTE: Carbide Inserts not included

Features

- One piece shank and cutter 3MT
- Suitable for steel, cast iron and non-ferrous metals
- True shoulder 90° cutter
- General purpose cutter
- Positive rake
- Suits 1/2" whitworth drawbars

Includes

- Lock key for insert

Product Brochure For M528

Recommended Accessories

L066

KYOCERA Carbide Inserts -
Milling

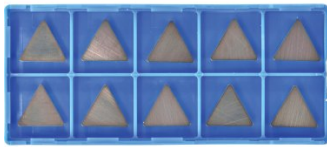

ML100

Cutter Part - Screw



ML200

Cutter Part - Clamp



ML300

Cutter Part - Spring



ML400

Cutter Part - Key

