

Product Brochure For M513

Face Mill 90° - Positive Rake - MS100T

Ø100mm

Insert tip not included

Ex GST
 \$130.00

Inc GST
 \$143.00



ORDER CODE:	M513
MODEL:	MS100T
Cutter Approach Angle (deg):	90°
D (mm):	100
D1 (mm):	~
H (mm):	50
d (lowercase):	32mm
Drawbar Thread:	~
Number of Inserts (No.):	6
Replacement Insert Tips:	(L066)
Nett Weight (kg):	1.85

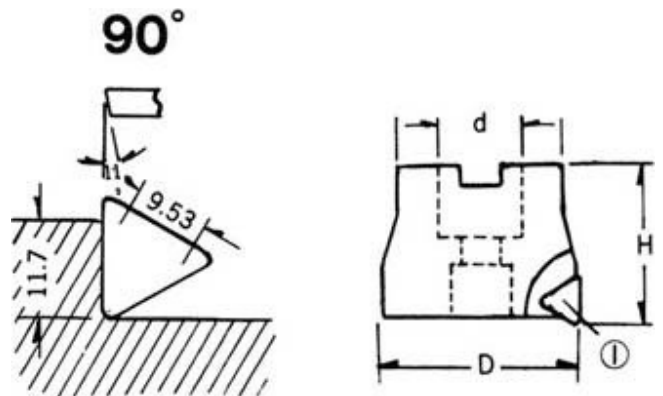

Description

POSITIVE RAKE FACE MILL - 100mm x 90°
 Use carbide inserts (ISO) TPKN1603 (L0661) or TPMN1603 (L066)
 NOTE: Carbide Inserts not included

Features

- Suitable for steel, cast iron and non-ferrous metals
- True shoulder 90° cutter
- General purpose cutter
- Positive rake

Includes

- Lock key for insert

Product Brochure For M513

Recommended Accessories

L066
KYOCERA Carbide Inserts -
Milling

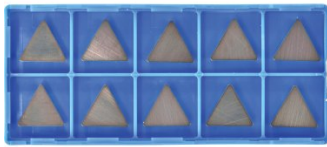

ML100
Cutter Part - Screw



ML200
Cutter Part - Clamp



ML300
Cutter Part - Spring



ML400
Cutter Part - Key



M537
Face Mill Arbor



M544
Face Mill Arbor



M554
Face Mill Arbor



Product Brochure For M513

T158

BT40-FMB32-45 Face Mill Arbor

