

Product Brochure For M1833

Precision Boring Head - BC-3

Ø75mm Head

Requires Spindle Arbor To Suit Machine



Description

Sturdy boring head suitable for roughing & finishing work. Fitted with 2 vertical and one cross hole for the boring bars. The boring head allows the boring bar to be adjusted at a right angle to the spindle axis. This feature makes it possible to position the boring cutter accurately to bore holes of varying diameters. The adjusting screw is hardened & ground and is a non reflecting satin chrome. The reading dial allows for adjustments of 0.01mm on the tool slide and is a direct reading.

Features

- Wide range of boring diameters and depths
- Calibrated micro adjusting screw via a hexagon key.
- 1-1/2" x 18TPI threaded body to mount optional arbors
- Accepts 18mm diameter boring bars
- Includes storage case for protection

ORDER CODE:	M1833
MODEL:	BC-3
Type:	Boring
D (mm):	75
H (mm):	80
d (lowercase) (mm):	18
W (mm):	~
h (lowercase) (mm):	~
Cross Hole Diameter (mm):	~
Centre Distance Between Holes (mm):	23
Micro Adjustment Travel (mm):	25
Nett Weight (kg):	3.2

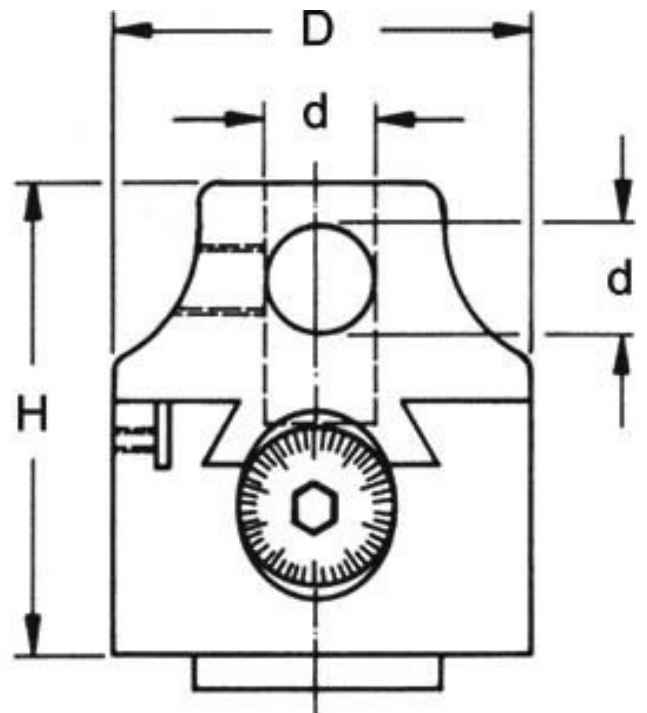

Product Brochure For M1833

Recommended Accessories

M181
Boring Bar Set - 12 piece



M181A
Boring Bar Set - 4 piece



M192
Boring Head Shank



M190
Boring Head Shank



M193
Boring Head Shank



M194
Boring Head Shank

