

Product Brochure For L78551

Automatic Loading Module - BODOR iLoader

3048mm x 1524mm / 1500mm x 1200mm / 1000mm x 1000mm

Working Area operation

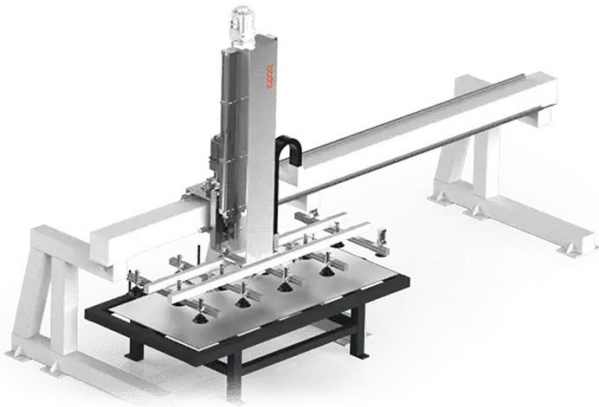

Please Call

ORDER CODE:	L78551
MODEL:	iLoader
Working Area (mm):	3048 x 1524 / 1500 x 1200 / 1000 x 1000
Maximum Feeding Plate Size:	-
Maximum Loading Weight (Kg):	700
Lifting method:	Sprocket, chain
Control Method:	Touch screen operation
Z-axis travel (mm):	400
Z-axis positioning accuracy (mm):	±1
Single Layer Bearing Weight (Kg):	-
X shaft stroke (feeding) (mm):	-
Storehouse Floor Height: (mm):	-
Weight (Kg):	-
Dimension (mm):	5000 x 2500 x 3100



Description

Intelligent Sheet Separating
 Avoid loading stuck sheets in a single loading as processing.

High-strength Linear Structure
 The loading layout uses the linear structure with stronger rigidity and better loading capacity, which loads a maximum of 20mm thickness for a single sheet.

Flexible Loading Size
 The size and type of the loading sheets are flexible and various.

Safety Interlock
 The safety interlock prevents operations from irreversible accident in safety.

Note:
 Please contact us so we can help you choose from a range of models tailored to your requirements

Features

- Suits P3 & C3 Models

Product Brochure For L78551

Specific Features

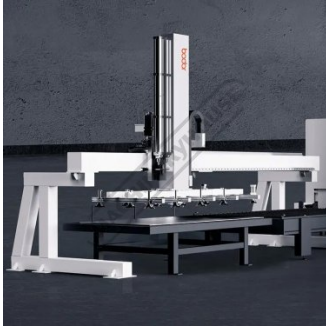

iLoader Shown Next To Machine