

Product Brochure For L7060

CNC Turning Centre - LYNX 220LSYC

Y Axis & Sub Spindle



ORDER CODE:	L7060
MODEL:	LYNX 220LSYC
Swing (mm):	600
Max Turning Diameter (mm):	300
Turning Length (mm):	510
Chuck Diameter (mm):	200
Bar Diameter Capacity (mm):	65
Tool Stations (No.):	12/24
Spindle Speed (rpm):	4500
Spindle Motor (kW):	15
Guideways:	LMG
Control:	Doosan Fanuc I Series
Programming:	EZI Guide I Conversational
C Axes Resolution (deg):	0.001
Milling Speed (rpm):	6000
Milling Collets:	ER20
Sub Chuck Diameter (mm):	135
Y Axis Travel (mm):	105 (±52.5)



Description

Basic Specifications

- 600mm Swing Over Bed
- 400mm Swing Over Saddle
- 510mm Turning Length
- 300mm Turning Ø
- 105mm (±52.5mm) Y Axis Travel
- 3600 (0.0010 Resolution) C Axes, Main & Sub Spindles
- 120kg Main Spindle Capacity, 300kg Shaft Work Capacity

Main Spindle

- 65mm Bar Capacity
- 200mm Ø Hydraulic Chuck
- 4500RPM Spindle Speed
- 15kW Spindle Power
- 169Nm Spindle Torque

Sub Spindle

- 35mm Bar Capacity
- 127mm Ø Hydraulic Chuck
- 6000RPM Spindle Speed
- 5.5kW Spindle Power
- 46Nm Spindle Torque

Turret

- BMT 45 Tool Mounting
- 6000RPM Live Tool Speed
- 3.7kW Live Tool Power
- 23.5Nm Live Tool Torque
- 24 Position / 12 Station Turret
- 20mm Square / 40 & 20mm Ø Tool Capacity
- ER20 Live Tool Collet Size
- Eppinger Preci-Flex Tooling System

CNC Control

- Doosan Fanuc I Series (0i-MD) CNC Controller

Product Brochure For L7060

- 10.4" Colour LCD Monitor
- Rigid-synchronised tapping
- Custom Macro B
- Ethernet Interface
- RS232 Interface
- USB & PCMCIA Memory Card Slot
- Doosan Ezi Guide "I" Conversational software:
- Graphical Turning Cycles
- Graphical Milling Cycles
- Full 3D Graphical Simulation
- Onboard G & M code assistance
- + more

Standard Equipment - Included

- 3 Jaw Hydraulic Power Chucks
- Chuck Cleaning Air Blast
- Eppinger rotary tool holders with Preci-Flex adapter set
- Coolant supply equipment
- Foot switches
- Transformer
- Full enclosure chip and coolant shield with front door interlock
- Hand tool kit
- Automatic lubrication equipment
- Comprehensive manuals incorporating, Operation, Maintenance, Programming, Spare Parts Diagrams, Hydraulic Schematics, Electrical Schematics and Ladder Diagrams.
- Safety name plates / tags where required
- Risk assessment
- Work light

Optional Equipment Included

- Chuck open close confirmation proximity switches
- Chip Conveyor (Side Discharge, Hinged Belt)
- Auto Tool Setter (Hydraulically operated)
- Coolant Oil Skimmer
- 7 Bar High Pressure Coolant
- Barfeed Interface
- Parts Catcher with Parts Conveyor
- Sub Spindle Work Ejector
- Chuck Cleaning Air Blast
- Auto Power Off Function

Standard Turret Tool Holder Package Included

- 1 x OD Tool Holder Main (R & L)
- 1 x DBL OD Tool Holder Main/Sub (R & L)
- 1 x DBL OD Tool Holder Main (R & L)
- 1 x DBL OD Tool Holder Sub (R & L)
- 1 x ID Tool Holder Main
- 1 x Double ID Tool Holder Sub
- 1 x Triple ID Tool Holder
- 1 x Face Tool Holder Main (R & L)
- 1 x Cut Off Tool Holder
- 1 x U Drill Cap Main
- 1 x U Drill Cap Sub
- 2 x Straight Milling Unit
- 1 x Angular Milling Unit
- 1 x Offset Angular Milling Unit
- 1 x Eppinger "Preci-Flex" Kit
- 1 x Boring Sleeve Kit Main
- 1 x Boring Sleeves Kit Sub
- 1 x U Drill Sleeve Kit
- 1 x ER 20 Milling Collet Set
- 1 x Hard & Soft Jaws Main and Sub

Local Service and Support

- Commissioning & Testing Included
- Comprehensive Operator Training Included
- Hare and Forbes In House Service And Applications Staff
- Ongoing Support For Life Of The Machine

Features

- Doosan Machine Tools changes its name to DN Solutions
- Read more at:

Product Brochure For L7060



Specific Features

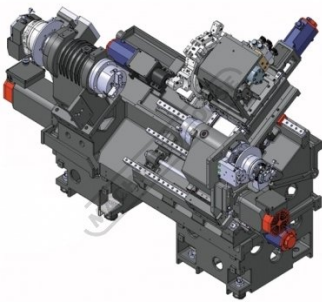

CNC LYNX Insert 1

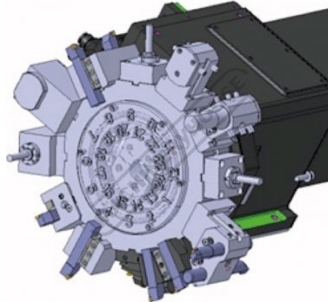

CNC LYNX Insert 2

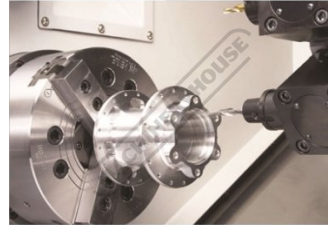

CNC LYNX Insert 3



CNC LYNX Insert 4

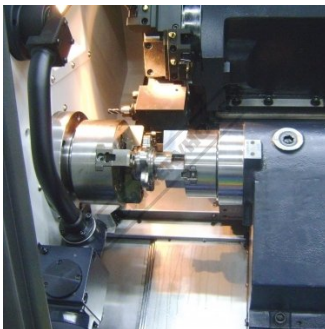

CNC LYNX Insert 5



Lynx220LSY Front View