

Product Brochure For L0539

KENNAMETAL Carbide Inserts - Turning - WNGP 080408 HP

Grade KC5410 - Aluminium
 5 Inserts Per Pack

Back In Stock Soon

Ex GST **Inc GST**
\$125.00 **\$137.50**



ORDER CODE:	L0539
MODEL:	WNGP 080408 HP
Grade:	KC5410
Application:	Aluminium
Pieces in Set (Qty):	5
[D] Insert IC Size (Inscribed Circle) (mm):	12.7
[D1] Insert Hole Size (mm):	5.16
[L10] Insert Cutting Edge Length (mm):	8.69
[S] Insert Thickness (mm):	4.76
[R?] Corner Radius (mm):	0.8
Relief Angle (Deg):	~
d (mm):	~
Insert shape (Style):	Trigon / Diamond

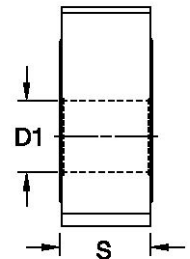
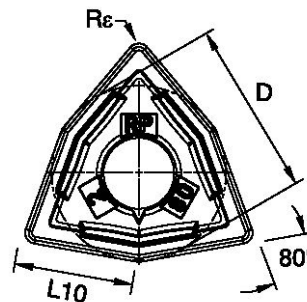

Description

KC5410 Grade - Aluminium

Manufactured in Germany, the KENNAMETAL KC5410 HP insert is designed for high-performance machining of aluminium and other non-ferrous materials. Its premium PVD-coated carbide grade provides excellent wear resistance, smooth chip flow and superior surface finishes. Ideal for roughing, semi-finishing and finishing operations, it also performs well on nylon and plastics.

The Kennametal WNGP 080408 (WNGP432K) in grade KC5410 is a specialized trigon (80-degree) carbide turning insert designed primarily for machining non-ferrous materials like aluminum and magnesium. The "HP" indicates a high-positive, light-feed chipbreaker designed to achieve excellent finishes and prevent built-up edges

Features

- Made in Germany for exceptional quality and precision.
- Premium PVD-coated insert on a highly deformation-resistant unalloyed substrate for extended tool life.
- Optimised high-positive cutting geometry ensures smooth cutting action, reduced cutting forces and excellent chip control
- Specifically designed for high-performance turning of aluminium. Also suitable for machining nylon, plastics and timber
- Supplied in a convenient pack of 5 inserts

Product Brochure For L0539

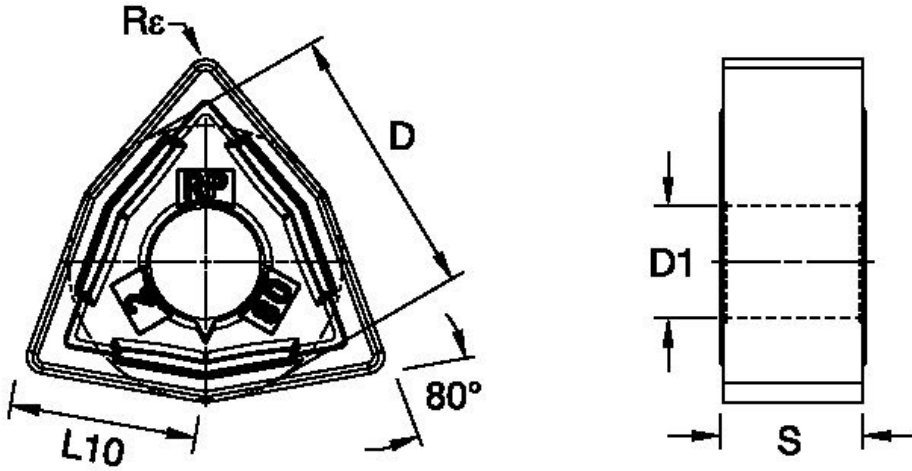

Specific Features

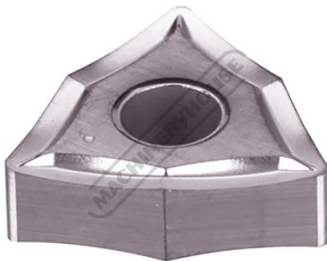

Tip

Recommended Accessories

L039
 Right Hand Turning Tool Holder

L040
 Left Hand Turning Tool Holder

L041
 Right Hand Turning Tool Holder

L042
 Left Hand Turning Tool Holder

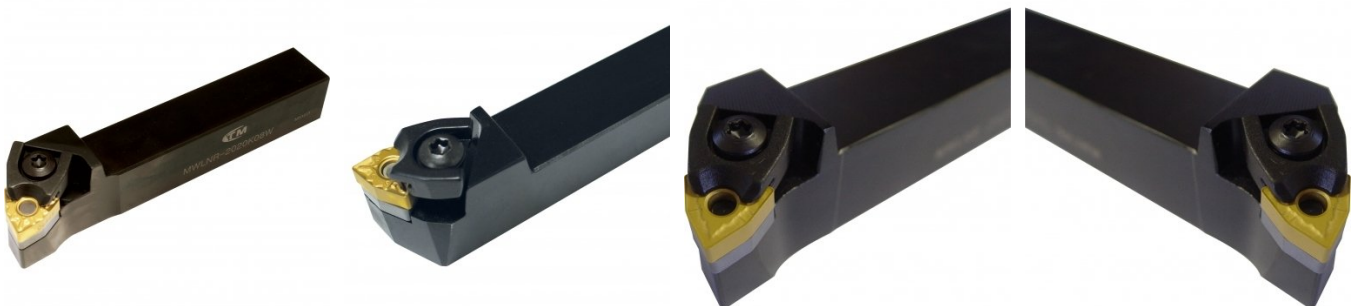

Product Brochure For L0539

L415
Right Hand Boring Bar



L416
Right Hand Boring Bar



L513
Seat to Suit Turning Tool
Holders



L514
Pin to Suit Turning Tool
Holders



L515
Clamp to Suit Turning Tool
Holders



L516
Clamp Screw to Suit Turning
Tool Holders

