

Product Brochure For I8131

Tube Fiber Laser Cutting - BODOR M-Series

6500mm-9200mm-12000mm Tube Lengths
 Max Tube Weight range 300Kg - 2000Kg

Please Call



MODEL:	M2 / M3 / M5
ORDER CODE (Type):	I8131
Cutting Length Capacity (mm):	6500 / 9200 / 12000
X Axis Max acceleration (G):	~
X/Y Axis Positioning accuracy (mm):	~
X/Y Axis Repeatability (mm):	~
Y Axis Maximum Speed (m/nim):	~
X Axis Maximum Speed (m/nim):	~
Z axis maximum speed (m/nim):	~
Max Chuck Rotating Speed (r/min):	110/M2 - 60/M3 - 37/M5
Max Load Capacity (kg):	300 - 2000
Standard Tube Support Holder:	Yes
Laser Type:	Fiber Laser
Laser Source:	BodorPower
Laser Head:	BodorGenius T
Control System:	BodorThinker Tube
Round Tube (mm):	M2-?8-?230mm / M3-?25-?356mm / M5 ?80-?510mm
Square Tube (mm):	~
Z-axis Active Obstacle Avoidance:	Yes
Auto Focus Laser Head:	Yes
Lightning Piercing:	Yes
Automatic tube inspection:	Yes
Over edge protection:	Yes
Drawing File (type):	G Code, DXF, DWG
Chuck Drive Type:	Pneumatic Chuck
Waste Trolley:	Yes
Centrifugal fan:	~
Bevel Tube Cutting (optional):	Yes
Slag cleaning module:	No
Machine Size (mm):	~
Nett Weight (kg):	~
Number of chucks:	4
Y Axis Max acceleration:	~



Description

Contact us to discuss your specific requirements and explore the best solution to suit your needs.

The M-Series can be configured in multiple ways from 6.5m / 9.2m / 12m in-feed and 6.5m / 9.2m / 12m out-feed.

The M-Series adopts a square-round structure chuck, which allows it to cut the maximum round tube diameter and the maximum square tube side length, providing users with more processing options.

The M-Series four chucks can be adapted to different processing scenarios. By intelligently switching between the heavy tube processing and high-efficiency modes, the machine empowers you to tackle diverse cutting tasks with ease.

Minimize manufacturing waste from the source. During operations, M series will help you utilize every piece of material to the largest extent possible, reducing waste and improving cost-effectiveness.

Features

- Four-Chuck Processing for Truly 0 Waste Material -With the four-chuck structure, when cutting the last section of any length of the tube, it can move the material forward or backward, truly achieving no waste material cutting.
- Automatic Unloading -Adopting the four-chuck structure, the entire cutting and unloading process of the M Series requires no manual intervention, eliminating safety risks.
- Follow-Up Rollers -(M2,M3) With the support of follow-up rollers and smart centering, the efficiency of loading and unloading is increased by 30%, ensuring the tube remains stable even during high-speed rotation, significantly enhancing cutting precision.
- Servo-Flipping Unloading -(M2,M3) Utilizing a new form of servo-flipping unloading reduces the workpiece's movement during cutting and

Product Brochure For I8131

- further enhances cutting precision.
- Single-Station Full-Automatic Loading and Unloading -(M5) The standard configuration of single-station loading and unloading device enables cyclic loading of tubes. The speed is increased by more than double compared to manual loading.
- Intelligent Cutting Modes Switching for All Processing Scenarios -According to different working conditions, the four chucks achieve intelligent pairing and automatically switch processing modes, perfectly adapting to any processing scenario to ensure optimal processing results.
- Ultra-Large Cutting Range -Featuring the square-round structure chuck, the M Series allows the cutting of round tubes with a maximum diameter equal to the maximum side length of square tubes, offering users more flexible processing options.
- Over Edge Protection for Tubes - Self-developed servo-following sensors and path avoidance algorithms can accurately sense obstacles in the position changes of the tube edges, and plan the obstacle avoidance route in advance to reduce the risk of laser head collision significantly.
- BodorThinker - BodorThinker is a high-end intelligent control system for a CNC laser cutter, featuring reliable stability, convenient installation and adjustment, safe production, multiple functionality, and robust performance. With BodorThinker, your laser cutting solutions can be modular, customized, automated and information-based.
- BodorNest Tube - BodorNest Tube is system designed for intelligent tube processing. It works with a diverse range of tube materials. Users can customize tube cutting layouts to fulfill different fabrication needs. This software increases material utilization rate by 15% and layout speed by 25%, facilitating the process of tube nesting. It also seamlessly integrates with other business software such as Tekla and Tribon.
- Weld Seam Identification - Optional - Automatic detection of weld seam positions ensures 100% precise identification and avoidance.
- Bevel cutting - Optional - typically, processed workpiece are left with gaps between one and another, which increase the workload of welding process as the gap filling and tube bevel grinding become necessary before the welding. However, the gap filling and bevel grinding process inevitably bring difficulties to the welding process and affect the welding quality.

Includes

- BodorGenius T: The specialized design of slender nozzle allows the machine to avoid interference and cut various types of tubes.
- Bodor Power: The backbone of any laser cutting system, and BodorPower takes it to the next level. This original laser source is the key to Bodor's high power processing (up to 60kW). It ensures longer lifespans, safer operations, and superior cutting results of every Bodor cutting machine.
- BodorThinker: Serves as the intelligent core of Bodor's laser cutting solutions. This control system integrates seamlessly with MES and ERP systems, facilitating automated production process management and information exchange through standardised communication protocols.
- 21.5 Inch Display'
- Local Service and Support
- Oxygen & Nitrogen Regulators with hoses
- *12 month warranty on machine parts & labor
- Commissioning & Testing Included (Metro Areas)
- Comprehensive Operator Training Included (Metro Areas)
- *Five year factory warranty on - Bodor Thinker Control System, Bodor Power Laser Source, Bodor Genius Laser Head.

Optional Accessories

- M series automation devices like M-Loader and M-Trans optimises material flow and boosts output of production

Specific Features



Servo Flipping



Zero waste

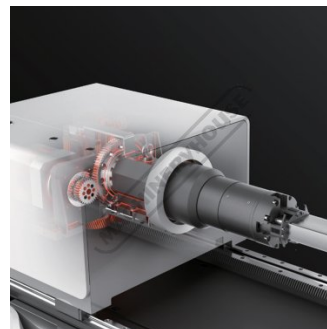

Pneumatic Chuck

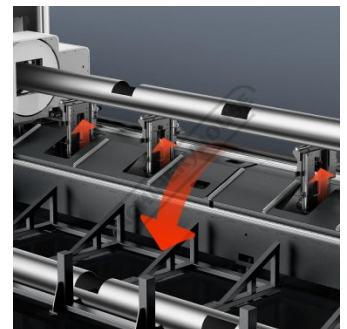

Automatic Unloading

Product Brochure For I8131



Follow Up Rollers M2 M3

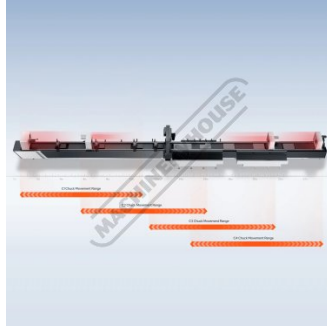

Chuck Range



BodorNest Tube



Profile



Profile 1



M5 Series

Recommended Accessories

C5051
Pilot Air Compressor

