

Product Brochure For I8000

CNC Turning Centres Series Details - LYNX 2100

Please Call



ORDER CODE:	I8000
MODEL:	LYNX 2100 Series
Swing (mm):	510-600
Max Turning Diameter (mm):	250-380
Turning Length (mm):	290-525
Chuck Diameter (mm):	150/210
Bar Diameter Capacity (mm):	45-65
Tool Stations (No.):	12/24
Spindle Speed (rpm):	4000-6000
Spindle Motor (kW):	15
Guideways:	LMG
Control:	Doosan Fanuc I Series
Programming:	EZI Guide I Conversational
C Axes Resolution (deg):	Optional
Milling Speed (rpm):	Optional
Milling Collets:	Optional
Sub Chuck Diameter (mm):	Optional
Y Axis Travel (mm):	Optional



**Features**

- Turret Tool Holder Set
- Eppinger BMT Live Tooling (C & Y Axis Models)
- Hydraulic Chuck
- Hard and Soft Jaws
- Coolant System
- Fully Enclosed Guarding with Door Interlocks
- Work Light
- Operator Training
- In House Service and Support Australia Wide

**Optional Accessories**

- C Axis and Live Tooling
- Y Axis
- Tailstock or Sub Spindle
- Tool Setter
- Parts Catcher
- Bar Feeders
- Chip Conveyors
- Oil Skimmer
- Mist Collector
- High Pressure Coolant
- Spindle Air Blast
- Auto Power Off
- Robot and Automation Interfaces
- Special Chucks and Workholding

- Doosan Machine Tools changes its name to DN Solutions
- Read more at:

Product Brochure For I8000



**Specific Features**



LYNX 2100LY Side



LYNX 2100LMS 1



LYNX 2100 LMS

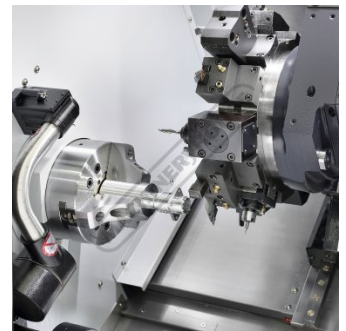

LYNX 2100LY



LYNX 2100TS

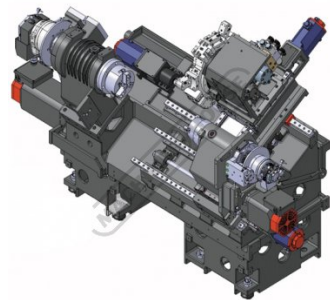

CNC LYNX Insert 1

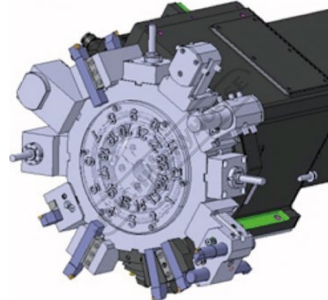

CNC LYNX Insert 2

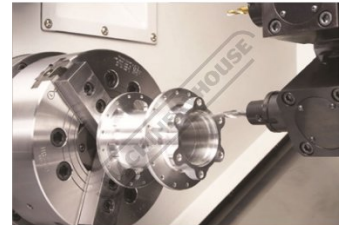

CNC LYNX Insert 3



CNC Lynx Insert 4

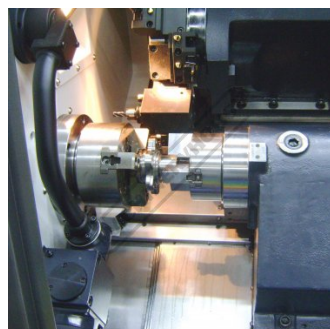

CNC LYNX Insert 5