

Product Brochure For D824

## Boring Sleeve - Straight - CHR 25-32

Suits CNC Lathes  
 Ø32mm x Ø25mm



**Ex GST**  
**\$70.00**

**Inc GST**  
**\$77.00**

ORDER CODE:	D824
MODEL:	CHR 25-32
Type:	Slot
OD (mm):	32
ID (mm):	25mm
L (mm):	86
L1 (mm):	56

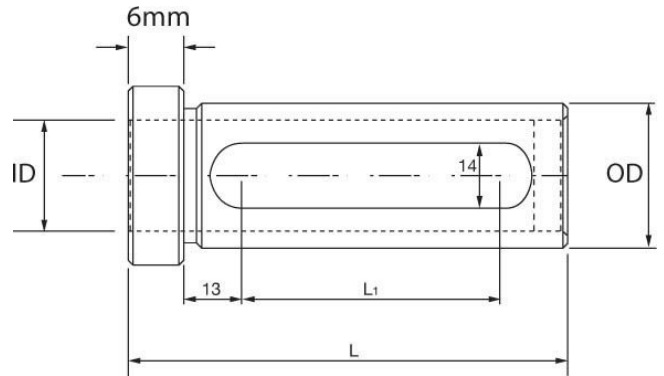

### Description

Used in the turrets of CNC lathes to hold boring bars and other cutting tools.  
 Universal design allows these sleeves to be fitted to all CNC machines with turrets

### Features

- Precision ground
- Slotted so that the turret clamp screws can clamp directly onto the boring bar or cutter

Product Brochure For D824

---

**Recommended Accessories**

L024

Right Hand Boring Bar

L416

Right Hand Boring Bar

