

Product Brochure For D7582

250mm Mini Digital Readout Scale - DC-10F250

Compact Scale
 5µm Resolution



ORDER CODE:	D7582
MODEL:	~
Type:	Compact Scale
Travel - Maximum (mm):	250
Overall Length (L) (mm):	388
Scale Resolution (µm):	5
Grating Pitch:	~
Accuracy (µm):	~
Output Signal:	~
Connector:	~
Cable Length (Metre):	3
Working Temperature (°C):	~
Sealing Protection Class:	~
Maximum Speed (M/min):	~
Reference Point:	~
Width x Height (W x H) (mm):	18 x 23.2
Backing Support Plate (Yes / No):	Yes



Description

Compatible with Easson digital readout displays

Features

- **DOUBLE SEAL DESIGNED SCALES:**
- The plastic seals of the transducer use an innovative material to offer superior oil resistance, high elastic recovery properties and durability, carefully designed lip geometry offer low slide resistance.
- **100% LASER CALIBRATION:**
- All glass grating transducers are individually inspected and calibrated by our in-house laser calibrator to ensure accuracy complies 100% with the specifications.
- **ADVANCED OPTICAL MEASURING SYSTEM:**
- The slide carrier of the DC-10F series scales, use a five bearing design for optical grating linear transducer which has been proven as the most reliable system design in today's market.
- The glass grating slide-ways are lapped, and JIS standard P5 grade bearings are used to achieve smooth and accurate movement and long working life.
- **D.I.Y. INSTALLATION:**
- An easy-to-follow D.I.Y. Installation Manual is supplied with each system, complete with illustrations and mounting brackets.

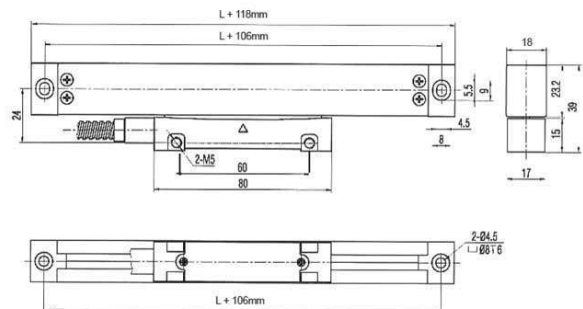

Product Brochure For D7582

Specific Features



DSub9 Male Plug

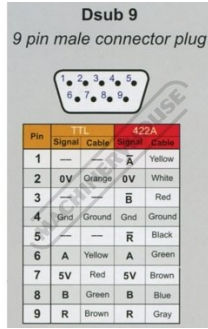

Dsub9 Wiring Diagram

Recommended Accessories

D709
 Easson Scales - Extension Cable



D710
 Easson Scales - Extension Cable



D772
 Digital Readout Scale Mounting Bracket Kit



D711
 Adaptor Cable



D712
 Adaptor Cable

