

Product Brochure For C721

## 4 Jaw Self Centring Lathe Chuck - K12-100

Ø100mm



**Ex GST**  
**\$170.00**

**Inc GST**  
**\$187.00**

ORDER CODE:	C721
Size (mm):	Ø100
Outside Jaw (mm):	2 - 30
Inside Jaw (mm):	30 - 80
Speed (rpm):	3500
D1 (mm):	72
D2 (mm):	84
D3 (bore) (mm):	22
H (mm):	74.5
H1 (mm):	55
h (mm):	3.5
z-d (mm):	3-M8
Nett Weight (kg):	3

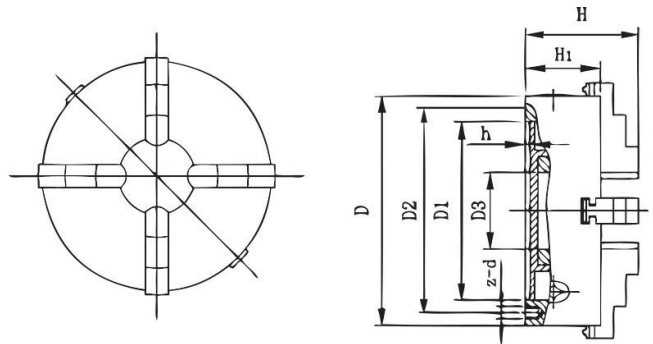

### Description

100mm 4-JAW SELF-CENTRING LATHE CHUCK  
 Manufactured from cast iron.  
 Available only in back mount.

### Includes

- 1 x set of outside hard jaws
- 1 x set of inside hard jaws
- 1 x key
- 1 x set of mounting screws

Product Brochure For C721

**Specific Features**



Back Plate Mount



Included Accessories



Front View

**Recommended Accessories**

L287

D1-4 Camlock Back Plate

L2875

D1-5 Camlock Back Plate

C2861

Chuck Key

