

Product Brochure For C155

Lever Block - HLB250

250kg x 1.5 Metre



**Ex GST**  
**\$109.09**

**Inc GST**  
**\$120.00**

ORDER CODE:	C155
MODEL:	HLB250
Lift Capacity (kg / Tonne):	250 / 0.25
Lift Height (Metre):	1.5
Weight (kg):	2.3

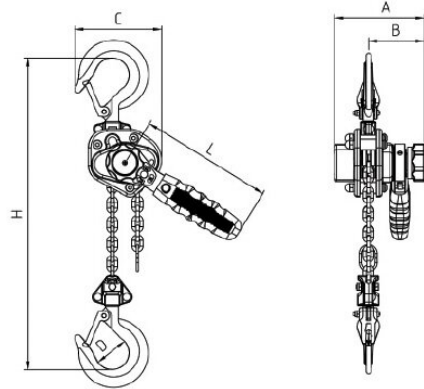

**Description**

HAFCO 250kg Lever Blocks are lightweight, compact, and ideal for rigging, construction, and mining applications. They feature a Grade 80 alloy load chain and a robust, space-saving steel body. The ID plates are made from stainless steel, and the unit contains no aluminium components. Each unit is AS 1418.2 compliant and supplied with a test certificate for quality assurance

MODEL	HLB250	HLB500
Capacity (kg)	250kg	500kg
Standards Lift (m)	1.5	1.5
Test Load (Tonne)	0.25	0.5
Headroom H (mm)	230	250
Effort on Lever to lift full load (N)	200	240
No. of chain falls	1	1
Dimensions (mm)	A (mm)	106
	B (mm)	66
	C (mm)	90
	D (mm)	32
Chain Size	4x12	4.3x12
Net Weight (kg)	2.3	2.8

**Features**

- Rated capacity: 250kg
- Ergonomically compact design
- Built for durability in harsh and rugged environments
- Quick and easy chain adjustment for fast load positioning
- Suitable for use in underground mining and heavy-duty applications
- Ball bearing-mounted to bottom hook enable smooth rotation under load
- Tested at a NATA-accredited facility in accordance with AS 1418.2
- Fully enclosed design with sealed gear and brake systems for superior protection and durability
- The short arm lever and precision gear ratio allow minimal effort to lift heavy loads with maximum
- HAFCO ID plates and rivets are made from stainless steel a non-conductive material for added safety and durability
- Each HAFCO Lever Block is load-tested to its rated capacity and supplied with a HAFCO test certificate, traceable to its stamped identification side plate.
- Standard Lift -(Metres) 1.5
- Test Load - (Tonne) 0.25
- Headroom - (H mm) 230
- Effort on lever to lift full load - (N) 200
- No. of chain falls - 1
- Chain Size (mm) - 4x12
- Length of lever handle - (L) 160mm

Product Brochure For C155

**Specific Features**



Main View Handle Down



Side View



Front View



Lever Handle Mechanism



Bottom Hook Assembly

**Recommended Accessories**

H300  
 Round Sling

H316  
 Flat Sling

H318  
 Flat Sling

H308  
 Round Sling



Product Brochure For C155

H307  
 Round Sling



H320  
 Flat Sling



H314  
 Round Sling



H322  
 Flat Sling



H312  
 Round Sling



H324  
 Flat Sling



C146  
 Girder Clamp



C147  
 Girder Trolley



C148  
 Girder Trolley



C188  
 Mobile Girder Rail Gantry



K088  
 Mobile Girder Rail Gantry  
 Package Deal



K090  
 Mobile Girder Rail Gantry  
 Package Deal

