

Product Brochure For S117B

Automatic Non-Ferrous Double Head Profile Cutting Machine - OMRM 113

Ø450mm Blade



ORDER CODE:	S117B
MODEL:	OMRM 113
Cutting Head Action (Auto-Manual):	Auto
Operation Type:	Swivel - Dual Mitre
Round Capacity @ 90° / 45° (mm):	~
Square Capacity @ 90° / 45° (mm):	~
Rectangle Capacity @ 90° / 45° (mm):	~
Compound Rectangle Capacity @ 45° x 45° (mm):	~
Compound Square Capacity @ 45° x 45° (mm):	~
Blade Size (D x B x T) (mm):	Ø450
Number of Teeth (No.):	~
Vice Clamping Fixture:	Pneumatic
Coolant System:	Optional
Table Working Height (with Stand) (mm):	~
Blade Speeds (rpm):	29820
Motor Power (kW / hp):	2 x 2.2 / 3
Voltage (V):	415
Machine Dimension (mm):	~
Nett Weight (kg):	910



Description

ALUMINIUM & PVC PROFILE CUTTING

Features

- Cutting length size and angle degree are entered from LCD-display on control panel
- Automatic head position for 45° and 90 °degrees, easy adjustment for intermediate angles
- Memory size of 2299 steps including quantity, length and angles of cutting
- Possibility of manual length size adjustment
- Magnetic rule length control system
- PLC control system
- Multi language support
- Repetitive cut program, angle cut – variable and fixed length – fixed angle
- Extra length cut program (over 4 metre.)
- Diameter of a diamond saw blade is 450 mm
- Output of disk is 148 mm that allows to make double profile cutting (74 mm x 2)
- Horizontal pneumatic clamping kit
- Adjustable cutting speed
- Single head operation possibility
- Industrial dust exhaust
- Conveyor for the movable head
- Intermediate profile support for long size cutting
- Particular care has been taken over the safety measures, both mechanical and electrical
- Power supply protects system from voltage overload
- Servo motor
- Linear rails head movement

Product Brochure For S117B

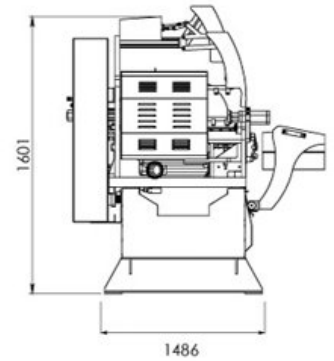
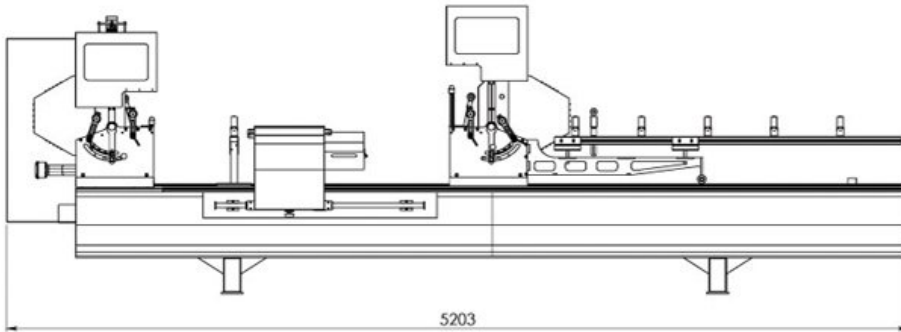

Specific Features



Control



Left Side Cutting Head



Right Side Cutting Head

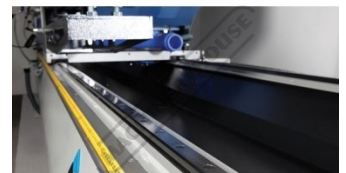

Linear Guideways

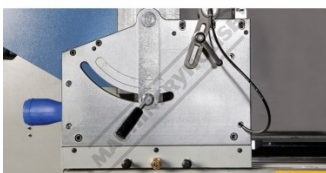

Adjustable Blade Angle



Material Protection Pads



Pneumatic Clamps



Wide Bed Support

Product Brochure For S117B

Recommended Accessories

S070

Metalium Neat Oil TCT ALU - 5 Litre



M800

Rubber Mat - Anti-Fatigue



M805

Rubber Mat - Anti-Fatigue

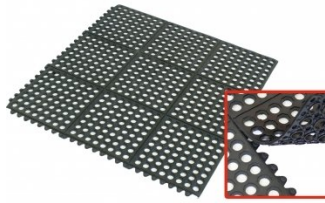

O000

SpillFix Universal Organic Absorbent



O043

Rust & Corrosion Preventive



O042

General Purpose Lubricant & Corrosion Inhibitor



O040

Rust & Corrosion Preventive



O044

Rust & Corrosion Preventive

