

Product Brochure For Q222

Dial Indicator - 34-222

0-1mm

Micron (Din Accuracy)



ORDER CODE:	Q222
Range (mm):	0 - 1
Graduations (mm):	0.001
A (mm):	32.5
B (mm):	21.5
C (mm):	8
D (mm):	57
E (mm):	19
F (mm):	17
G (mm):	6.35
H (mm):	8

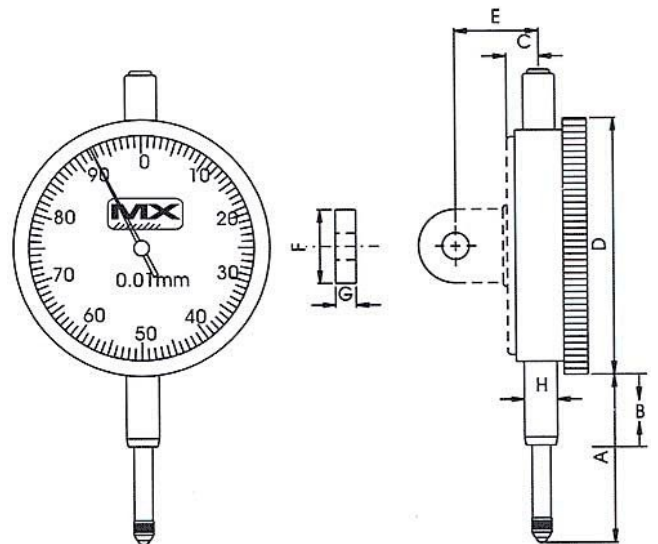

Features

- Smooth 10 jewel movement
- In-out tolerance marker
- Dial reads 1µm
- Flat glass
- Protected top spindle extension
- Back plate lug
- Metal bezel
- Peach shape body
- Supplied in foam lined plastic case with test reports

Product Brochure For Q222

Recommended Accessories

Q2165
 Ø10mm Flat Contact for Dial Indicators



Q2167
 Contact Point for Dial Indicators



M050
 Magnetic Base - Standard



M051
 Magnetic Base - Deluxe - One Lock



Q430
 Magnetic Base - Small



Q435
 Magnetic Base - Large



Q4351
 Magnetic Base - Large



Q436
 Magnetic Base - One Lock (Large)

