

Product Brochure For M515

Face Mill 45° - Super High-Rake - F45SE12-D50

Ø50mm

Insert tip not included

On Sale

Ex GST

Inc GST

~~\$120.00~~

~~\$132.00~~

\$108.18

\$119.00



| | |
|------------------------------|-------------|
| ORDER CODE: | M515 |
| MODEL: | F45SE12-D50 |
| Cutter Approach Angle (deg): | 45° |
| D (mm): | 50 |
| D1 (mm): | 64 |
| H (mm): | 40 |
| d (lowercase): | 22mm |
| Drawbar Thread: | - |
| Number of Inserts (No.): | 4 |
| Replacement Insert Tips: | (L065) |
| Nett Weight (kg): | 0.60 |



Description

SUPER HIGH-RAKE FACE MILL - 50mm x 45°
 Use carbide inserts (ISO) SEKT1204 (L065)
 NOTE: Carbide Inserts not included

Features

- Suitable for low horsepower machines where rapid metal removal is required.
- Suitable for steel, cast iron and non-ferrous metals
- Positive rake

Includes

- Lock key for insert

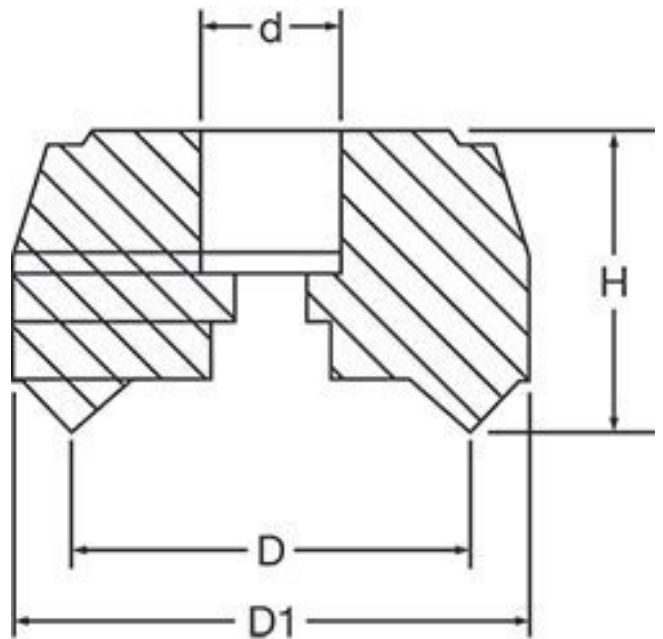

Product Brochure For M515

Recommended Accessories

L065

KYOCERA Carbide Inserts -
Milling



ML090

Cutter Part - Screw



L538

Key to Suit Tool Holder



M562

Face Mill Arbor



M535

Face Mill Arbor



M540

Face Mill Arbor



M550

Face Mill Arbor



T150

BT40-FMB22-45 Face Mill Arbor



Product Brochure For M515

T151

BT40-FMB22-90 Face Mill Arbor

